

Technical Specifications
Turbine gas meter, series Type-C, iM-TM-Q

Applications:	Natural gas / Argon / Butane / Ethane Nitrogen / Carbon dioxide / Carbon monoxide Air / Methane / Pentane / Propane	
Meter body:	strength calculation - according RTOD & EN 13445	
	material - Cast aluminum	
	flange connection - according to ASME B16.5/EN1092 raised faced	
	Pressure rating & mounting - see table below	
	surface treatment - hard anodized	
	installation length (L) - see table below	
	design pressure - 20 bar	
	design temperature range - -25° / +65° C	
	max. operating pressure - according flange classification, see below table	
	operating temp. range - -25° / +65° C	
Feature:	flow direction - Horizontal/Vertical	
	pressure point - Standard EO6 pipe-port - On request ¼ NPT plugged	
	temperature measuring point - cable gland 6mm (2 pocket if No HF on Shaft, 1x pocket if HF on Shaft required)	
	Lubrication system - Standard: manual Oil-Pump	
	high frequency sensor - Optional HF ONLY on Main Shaft	
Index:	Standard: 8 digit index , on request Optical Encoder Index	
	low frequency sensor - 2x low frequency NO reed contact & 1 x anti fraude NC reed contact	
	reading - cubic meters	
Calibration:	authority - Standard QA calibration	
	rangeability - determined by approval & technical Qmin. See table below	
	accuracy - $Q_{min} \leq Q \leq Q_t$ % & $Q_t \leq Q \leq Q_{max} \pm 1\%$ (Q_t according to EN12261)	
	repeatability - 0.2% or better	
Approvals:	Compliant with part of EN12261	
	ATEX Compliant with 2014/34/EU - Receipt TUV n° 0206120	
	PED Compliant with 2014/68/EU - Lloyd's register Certificate 0038/PED/MLN PRJ11090550/02/01	
Documents:	declaration of conformity, manual , calibrations certificate, installation instructions	
Options:	on request	

Available Size:

Rating	Qmax.	Qmin.	Size	LF pulses	Length	Weight	Mounting Bolts		
range	m ³ /h	m ³ /h	metric (inch)	Imp. /m ³	mm	Kg	PN10	PN16	ANSI 125-150
G40	65	13	50 (2")	10	150	5,5	4 x M16	4 x M16	4 x 5/8 UNC
G65	100	10		10					
G100	160	16		1					
G100	160	8	80 (3")	1	120	6,8	8 x M16	8 x M16	4 x 5/8 UNC
G160	250	13		1					
G250	400	20		1					
G400	650	32		1					
G160	250	13	100 (4")	1	150	8,2	8 x M16	8 x M16	8 x 5/8 UNC
G250	400	20		1					
G400	650	32		1					
G650	1000	50		1					

Note:

Overall Dimensions
Turbine gas meter, series Type-C, iM-TM-Q

This drawing lists main dimensions of IMTM-Q meter housing
 made of aluminum PN16 or ANSI150 type only.
 According to customer requests, B and/or H dimension(s) may change
 (example, when cryogenic long neck, HF shaft/wheel, and/or high pressure oil pump are used).

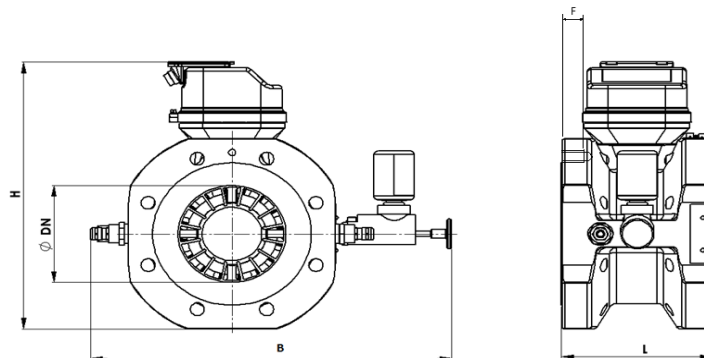

Aluminum body PN16 & ANSI150

Size	DN	L ± 5 mm [mm]	B ± 10 mm [mm]	H ± 10 mm [mm]	F min [mm]
50 mm (2")	50	150	307	240	35
80 mm (3")	80	120	330	270	40
100 mm (4")	100	150	360	300	40